

Sec 4 Normal (Academic) Education and Career Guidance

HOUGANG
SECONDARY SCHOOL



Ms Juan Pei Ling
Education and Career Guidance Counsellor

Education and Career Guidance - ECG

Exploring Opportunities

Post-secondary education pathways
Career Aspirations

Discovering Purpose

Values, interests, personality,
skills & strengths



Staying Relevant

Working towards education
and career goals

Post Sec Pathways for Normal (Academic)

HOUGANG
SECONDARY SCHOOL



Post-Secondary Pathway for N(A) students

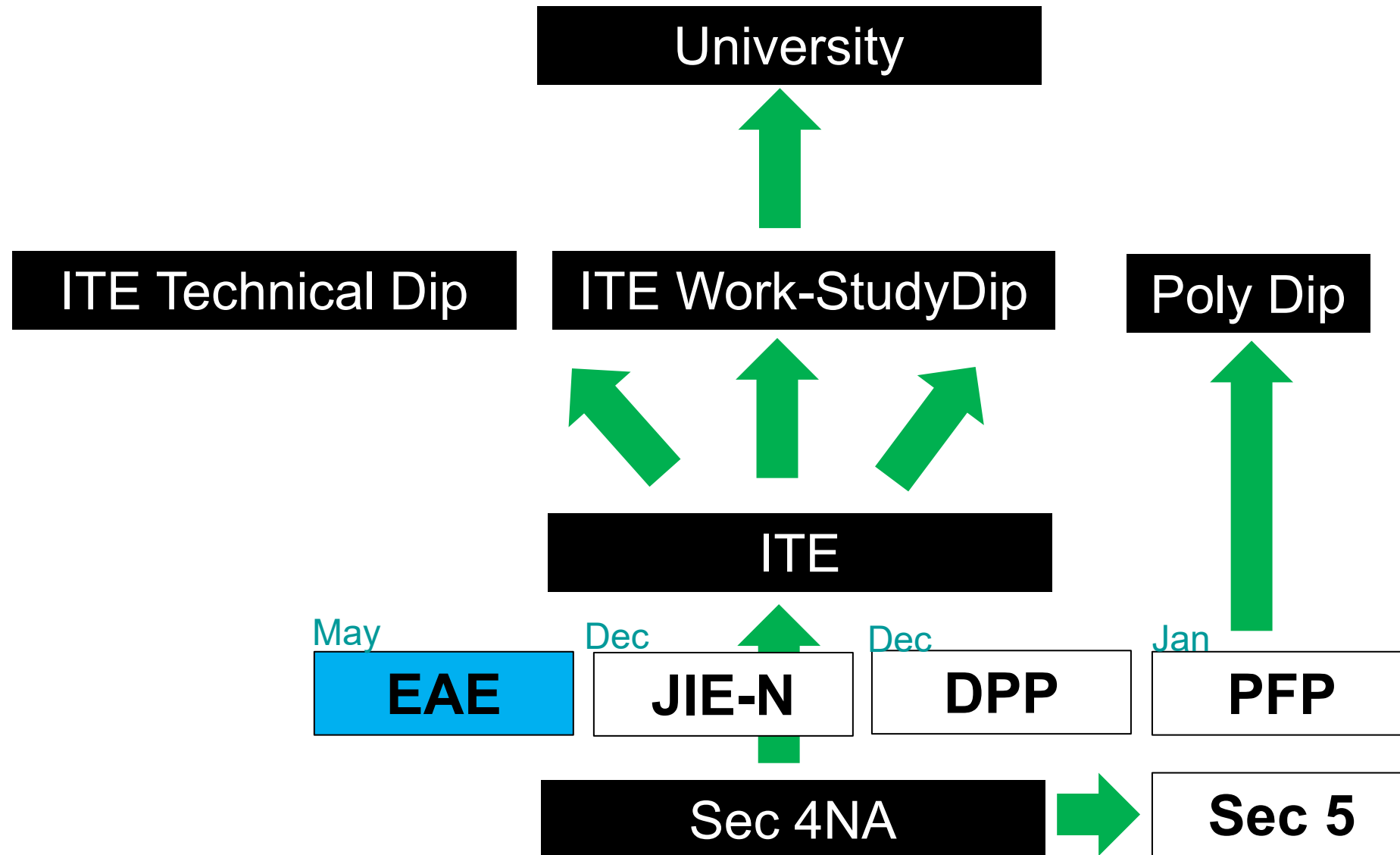



Post Sec Pathways – NA/NT



All pathways lead to University!

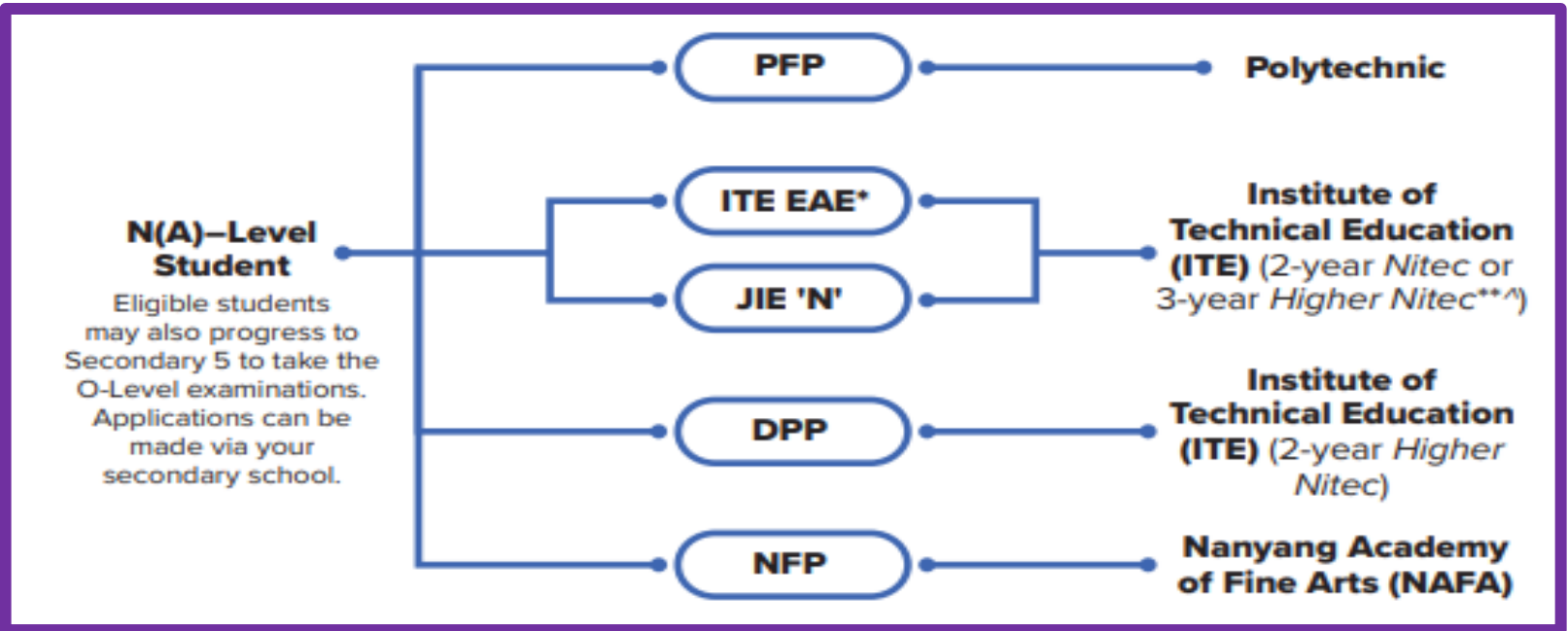

PFP	Polytechnic Foundation Programme ELMAB3 ≤ 12	For N(A) Students ONLY Aggregate Computation: ELMAB3 [EL + MA + Best 3 other subjects] <i>N(A) Grade 6 cannot be used for ELMAB3 computation.</i>
NFP	NAFA Foundation Programme ELMAB3 ≤ 15	
Sec 5	Progression to O-Level via Sec 5 ELMAB3 ≤ 19* (check with school on its practice)	
DPP JIE'H'	Direct-Entry-Scheme to Polytechnic Programme (2-yr Higher Nitec → Mapped to Poly course) ELMAB3 ≤ 19	
JIE 'N'	ITE 3-yr Higher Nitec / 2-yr Nitec Best 4 subjects (check subject requirements)	For Both N(A) & N(T) Students
Train-eeship	ITE Traineeship Scheme	



Overview of Post-Secondary Education Institutions (PSEIs)

Polytechnics

- 5 Polytechnics
- **Work-ready Diploma** and for admissions to universities
- Applied, practice-based learning experience with internships

Institute of Technical Education

- 3 campuses
- **Work-ready Higher NITEC Certification** and for admissions for Diploma
- Hands-on, practice-based learning with internships



Changes in Education Landscape

Post-Secondary

1. Recent changes to **A-level Curriculum**
2. Expansion and changes in **Polytechnic Foundation Programme (PFP)**
3. New ITE curriculum with **shortened route to Higher Nitec**
4. **More progression pathways for ITE graduates**, including offering of Work-Study and Technical Diplomas by ITE

Institutes of Higher Learning (IHL)

5. Expansion of **Aptitude-Based Admissions at Autonomous Universities**
6. **Interdisciplinary learning** in IHL
7. **University of the Arts Singapore** in addition to the **six autonomous universities**



Starting from the 2026 intake, students will be admitted to the PFP in 3 broad clusters instead of a specific diploma programme.

3 BROAD CLUSTERS

Sciences

Humanities, Art, Media and Business

Design, Engineering and Technology
NYP and TP offer as two sub-clusters: (i) Design and
(ii) Engineering & Technology

DIPLOMA SPECIFIC

Nursing (NP and NYP)

Early Childhood Development & Education
course (NP and TP)

Tamil Studies with Early Education course
(NP)



PFP (Applies to NA only)

■ PFP Eligibility Criteria

Gross ELMAB3 \leq 12; English set at grade \leq 3 for all clusters

- There are additional grade, interview or test requirements to *progress to selected courses within each cluster*

Polytechnic Foundation Programme

For Sec 4NA students

Relevant subjects per PFP Cluster for AY2026

Science Cluster		Design, Engrg, Technology Cluster*		Humanities Cluster	
Subj	Grade	Subj	Grade	Subj	Grade
Eng Lang	3	Eng Lang	3	Eng Lang	3
Math Syll. A or A Math	3	Math Syll. A or A Math	3	Math Syll. A or A Math	3
Any 1 relevant subj. <ul style="list-style-type: none"> • Design & Tech. • Food & Nutrition / Nutrition & Food Science • Sci. (Chem./Phy.) • Sci. (Phy./ Bio) • Sci. (Bio / Chem.) 	3	Any 1 relevant subj. <ul style="list-style-type: none"> • Design & Tech. • Food & Nutrition / Nutrition & Food Science • Sci. (Chem./Phy.) • Sci. (Phy./ Bio) • Sci. (Bio / Chem.) 	3	Any 1 relevant subject <ul style="list-style-type: none"> • Art • Humanities (SS/Geog.) • Humanities (SS/Hist.) • Literature in English • Principles of Accounts 	3
Any other 2 subi.	4	Any other 2 subi.	4	Any other 2 subi.	4

*Incl. Sub-Clusters Source: <https://www.moe.gov.sg/post-secondary/admissions/pfp-2026-intake>).



Polytechnic Foundation Programme

For Sec 4NA students

Relevant subjects for PFP for AY2026

Nursing (NP, NYP)		Early Childhood (NP, TP)		Tamil Studies with Early Childhood (NP)	
Subj	Grade	Subj	Grade	Subj	Grade
Eng Lang	3	Eng Lang	3	Eng Lang	3
Math Syll. A or A Math	3	Math Syll. A or A Math	3	Math Syll. A or A Math	3
Any 1 relevant subj. <ul style="list-style-type: none"> • Design & Tech. • Food & Nutrition / Nutrition & Food Science • Sci. (Chem./Phy.) • Sci. (Phy./ Bio) • Sci. (Bio / Chem.) 	3	Any 1 relevant subj. <ul style="list-style-type: none"> • Art • Humanities (SS/Geog.) • Humanities (SS/Hist.) • Literature in English • Principles of Accounts 	3	Any 1 relevant subject <ul style="list-style-type: none"> • Art • Humanities (SS/Geog.) • Humanities (SS/Hist.) • Literature in English • Principles of Accounts 	3
Any other 2 subi.	4	Any other 2 subi.	4	Any other 2 subi.	4

Source: <https://www.moe.gov.sg/post-secondary/admissions/pfp-2026-intake>



Institute of Technical Education

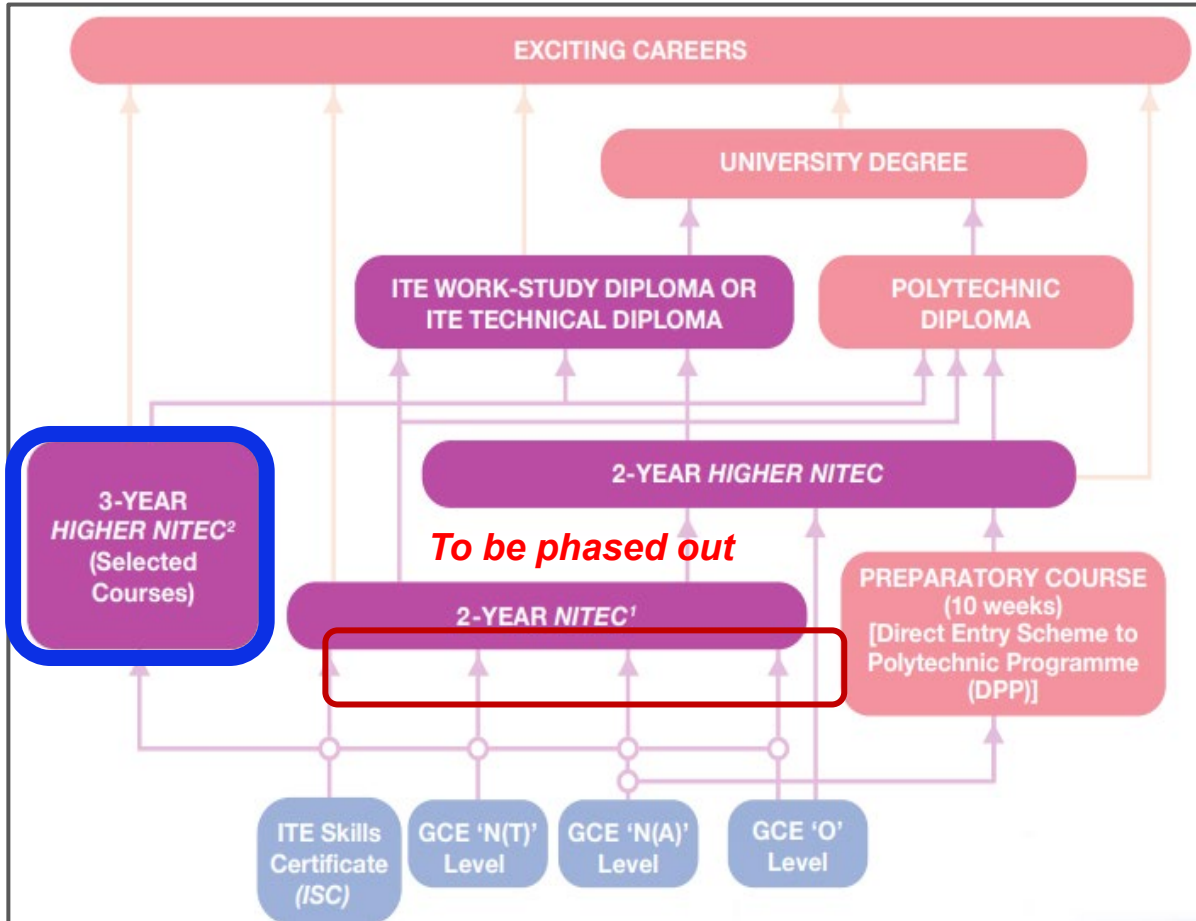

More pathways to polys for ITE students from 2027



THE STRAITS TIMES

Amelia Teng
Education Correspondent

UPDATED JUL 21, 2023, 11:22 PM SGT -

More **Institute of Technical Education (ITE) students will be given the chance to move on to polytechnics** from academic year 2027, as part of efforts to expand pathways and choices for students.

Those pursuing a Higher Nitec qualification at ITE will be **guaranteed admission to a polytechnic course related to their Higher Nitec course**, if they attain a grade point average (GPA) of **3.5 or above**.

3-year Higher Nitec at ITE

For Sec 4NA and NT students

- **3-year Higher NITEC offers a streamlined curriculum** and students gain exposure to modules in their sector in year 1 before specializing later. Includes 2 internships (Yr 2 & 3)
- Gradual transition from 2-year NITEC to 3-year Higher NITEC courses.
From AY2026, all courses will be 3-year Higher NITEC courses.
- **Aggregate score is computed based on 4 subjects**, including pre-requisite subjects and bonus points. Minimum Entry requirements of the courses differ. Some examples:
 - **3 GCE 'N' Passes** in **English, Mathematics** and 1 other subject
 - **3 GCE 'N' Passes** in **Mathematics** *or* **Science*** and 2 other subjects
 - **3 GCE 'N' Passes** in **English** and 2 other subjects
 - **3 GCE 'N' Passes** in **Mathematics** and 2 other subjects
 - Completed N-level
- After graduating from Higher Nitec, ITE graduates can enjoy the **ITE progression Award** when they pursue diploma:
 - Top-up of \$5000 to Post-Secondary Education Account upon enrolment into Poly course
 - Top-up of \$10,000 to CPF OA upon completion of Poly course



Joint Intake Exercise - JIE N / JIE H

Guiding Students To Make Their 12 Choices



Passion Basket

First 3 - 4 Choices

Consider courses that **most align** with your Values, Interests, Personality & Skills (V.I.P.S) and strengths.



Practical Basket

Next 4 Choices

Choose courses you are **interested in** and stand a **good chance in securing**. (where your net score is **within** the range of the last year's aggregate score).



Prudence Basket

Last 4 Choices

Include alternative courses and institutions where the latest aggregate scores are **higher** than yours. With this, your chances of securing a place will be higher.

Restricted - Only for Internal Circulation

Maximize the number of course choices in each application.

- **JIE 'N' and DPP (JIE 'H') are separate applications**, and each has **12 choices**.
- PFP (application in mid Jan 2025) has **5 choices**.



Grade Conversion & Bonus Points for ITE Aggregate Points for JIE N admissions

O-Level	N(A)	ITE Aggregate Point for JIE'N'
A1 – D7	1, 2, 3	1
E8	4	2
9	5	3
-	6	4
-	-	5

CCA Grade	Bonus Points
Excellent	2
Good	1

Bonus points not taken into account for course eligibility. Used only for course posting.



MOE Coursefinder

<https://www.hougangsec.moe.edu.sg/quick-links/For-Students/>

- To explore ITE courses with latest cut off points

Example

MySkillsFuture **ECG Bookcase** **CourseFinder**

[MySkillsFuture For Secondary Students](#) [Education and Career Guidance Bookcase](#) [MOE Course Finder](#)

▼ Criteria [Clear all](#)

Colleges [^](#)

ITE College Central

Aggregate [^](#)

Aggregate type [Clear](#)

Select an aggregate type ▼

Aggregate score

0

Field of study [^](#)

Applied and Health Sciences

Business and Services

Electronics and Info-comm Technology

Engineering

Hospitality

Media and Design

Qualification [^](#)

GCE N-Level

Courses in ITE ← 1 of 3 →

Showing 50 courses

Qualifications: GCE N-Level x

Higher Nitec in AI Applications (3 years) [♥](#)

Admission Type: JIEN, ITE EAE

ITE College Central, ITE College West

Qualification Required : GCE N-Level

Higher Nitec in Accounting (3 years) [♥](#)

Admission Type: JIEN, ITE EAE

ITE College Central, ITE College East, ITE College West

Qualification Required : GCE N-Level

Higher Nitec in Applied Food Science (3 years) [♥](#)

Admission Type: JIEN, ITE EAE

ITE College East

Qualification Required : GCE N-Level

Higher Nitec in Architectural Technology (3 years) [♥](#)

Admission Type: JIEN, ITE EAE

School Website

Aptitude Based Admissions (ABA) – EAE

HOUGANG
SECONDARY SCHOOL





What is EAE?

- For students who have **strong aptitude and interest** in specific fields of study.
- Students who have applied will be assessed through different modes e.g. Interviews.
- These will take place before their national examinations.
- **The students who were successful in their EAE application will still need to meet the two criteria.**

Criteria : 1. Min. Entry Requirements (MERs)
2. Subject pre-requisites.



Why EAE?

- Secure a place in a competitive ITE course.
- Just make sure N level results meet the minimum entry requirements (MERs) for the course.

What are MERs?

Minimum Entry Requirements (MERs)

Some possible examples:

- **3 GCE 'N' Passes** in **English, Mathematics** and 1 other subject
- **3 GCE 'N' Passes** in **Mathematics** *or* **Science*** and 2 other subjects
- **3 GCE 'N' Passes** in **English** and 2 other subjects
- **3 GCE 'N' Passes** in **Mathematics** and 2 other subjects
- Completed N-level

OR
2 GCE 'O' Grades
(Grade 1-8) in **any**
two subjects

GCE 'N' Pass refers to Grade A-D (NT) or Grade 1-5 (NA).

*Mobile Robotics, Smart Electrical Technology, IoT Applications, Mechanical Design & Automation, and Mobile Web Applications subjects can be used **in lieu of Science** for admission to these courses.



Refer to the **JIE booklet** for updated information.



What are MERs?

Courses with MER “Completed N-Level”

Reminder:
Eligibility to apply
does NOT
guarantee
placement.

Refer to the [JIE booklet](#) for
updated information.

School	Course
Business & Services	Higher Nitec in Beauty & Wellness Management (3 years)
	Higher Nitec in Hairdressing and Salon Management (3 years)
	Higher Nitec in Logistics and Supply Chain Management (3 years)
	Higher Nitec in Retail and Online Business (3 years)
Design & Media	Higher Nitec in Technical Theatre & Production (3 years)
	Higher Nitec in Film & Video Production (3 years)
	Higher Nitec in Communication Design (3 years)
	Higher Nitec in Interior & Product Design (3 years)
	Higher Nitec in Visual Merchandising (3 years)
Electronics & Info-comm Technology	Higher Nitec in Security System Integration (3 years)
Engineering	Nitec in Automotive Technology
	Nitec in Mechanical Technology
	Higher Nitec in Landscape Management & Design (3 years)
	Higher Nitec in Facilities Management & Engineering (3 years)
	Higher Nitec in Vertical Transportation (3 years)
Hospitality	Higher Nitec in Culinary Arts (3 years)



What to prepare?

General application

- Write Up - Personal, Talent and Achievement.
- Aptitude test, Auditions, Trials.
- Interview – Individual / Group, Online or Onsite.
- Portfolio.

Good Examples Write up

About yourself | About your interest and related achievement or exposure | What plan after completing the ITE course?

This applicant was offered and accepted into Nitec in Nursing:

Making a difference in someone's life has been my **aspiration since young**. I've gained many skills from my CCA, NCDC. With the **interest to explore the world of healthcare**, I have **completed 1. Basic Cardiac Life Support, 2. Urban Search and Rescue specialisation course, 3. Ignite Skills Challenge 2019**. I am nominated for the **Community First Responder Award**, achieved the **Eduwise EAGLES Award**, and attained bronze level of the **NVQs**. After gaining exposure to higher learning and first aid, I have become more determined to study nursing so to prepare quality **healthcare for the community with passion and care**.

Successful applicant for the 3-Year Higher Nitec in Sport Management:

I have selected this course as my 1st choice because I have a **deep passion for fitness and sports**. I developed **interest in organising sporting events** because it is something I have always wanted to do everytime I participate in a sports event. I participated in NSG which is a school tournament and I participated in it because of my CCA. In my experience as a PE Representative and a Sports Leader in school, I gained knowledge in the **maintenance and upkeep of sports equipment and facilities**. As an avid footballer, my ambition is to become a football coach and I hope to specialise in coaching and gain more knowledge about **sports and fitness in this course**.



What to include in a Portfolio?

Exam Results	CCA Testimonial	Relevant Projects
Community Service	Samples of Creative Work (if applicable)	

Various Interview Formats



Face-to-Face/Online Video Interview



Individual Interviews of 5-10 minutes (1 interviewer to 1 student)



Panel Interviews (a few interviewers to 1 student)



Group Interviews (1 or a few interviewers to a few students)



SIL & EAE Preparation

Aligning SIL project to EAE assessment criteria.

Successful ITE EAE Nursing

Introduction

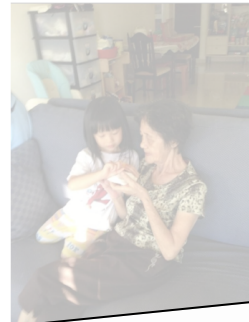

Who am I? I am Marshall Chew Qi Yuan, I am a Hougean in Hougang Secondary School; my co-curricular activity (CCA) is Red cross youth. I liked to take care of my grandmother since young. Red cross has inspired me more, wanting to know about the healthcare industry. I always

Conclusion

To conclude, learning hokkien is beneficial for me in the future, as Singapore has an aging population. Some elderly only speaks know their own dialect, and knowing little Mandarin to no English. Learning hokkien makes part of my passion towards nursing career as well. This would allow me to lead better conversations and communicate with the elderly; besides I am quite sociable, and making talking the elderly with the knowledge of hokkien easier for me. To continue this dedication of learning hokkien, I will practice talking with my parents and grandparents in hokkien more often to polish the skill. In an additional tool for my course wanting to get into Nursing.

What I chose and why

For my EAE application, I chose dialect as Singapore has an aging population, there are many elderly people who may not speak or understand English. Choosing dialect for my EAE would be let me be able to better communicate with this group, and to have lead conversations with the elderly, and be able to understand their needs without being confused by what they are saying. Besides benefiting myself, the elderly can communicate with people like myself whom is not in their generation, without communication barriers.

Learning Hokkien an option for me. I can use this language especially when I want to Nursing, a bonus point when I know different languages. I can better communicate with people bringing myself closer to the patients.

Evidence

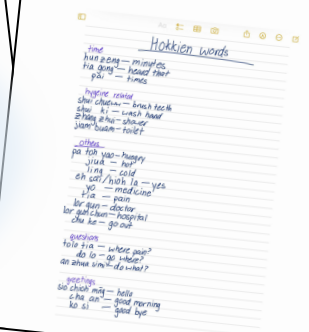

Through this experience of learning hokkien, I had some highs and lows. There were some parts where I was quite good at, and certain areas where I was unsure of. With the aid of Google and my family members' assistance knowing the dialect to do my SIL EAE project joyful and unpleasant at the same time. I used Google-translate for my research, such as searching words that I would want to know, and going onto YouTube for the pronunciations. When I managed to get it, I would ask my parents for confirmation if the word is read correctly. However, there were some low points during the project, like having no motivation or was too busy with my studies, on other examinations, leading me to waste time on procrastination and having to study for my examinations. This cause me to be unable to focus on continuing practice the dialect when nobody using with me.

Introduction

In secondary school, I was chosen to be in Red Cross youth for CCA. In this uniform group, I have learnt first aid skills and leadership skills. I was taught to how to work in groups and to have more confidence to present myself to strangers and to better handle tasks. First aid skills that I learnt includes handling injuries both in demonstration and in real life situations. From the start casualty transportation with a stretcher. From the start of secondary 2, I struggled to lead the juniors. Fortunately, I adapted and lead them to be confident leaders and to be more vocal and not soft spoken. By then when I reached secondary 3, I was able to lead my juniors and I can confidently teach them on how to master foot-drills and commands, and first aid skills. From this experience throughout the year, I am able to reflect, knowing my strengths and weaknesses. Although my confidence is still not there yet, I know that I would be able to lead others soon, to be a role model to others, and show empathy to individuals.





Student Benjamin's Story

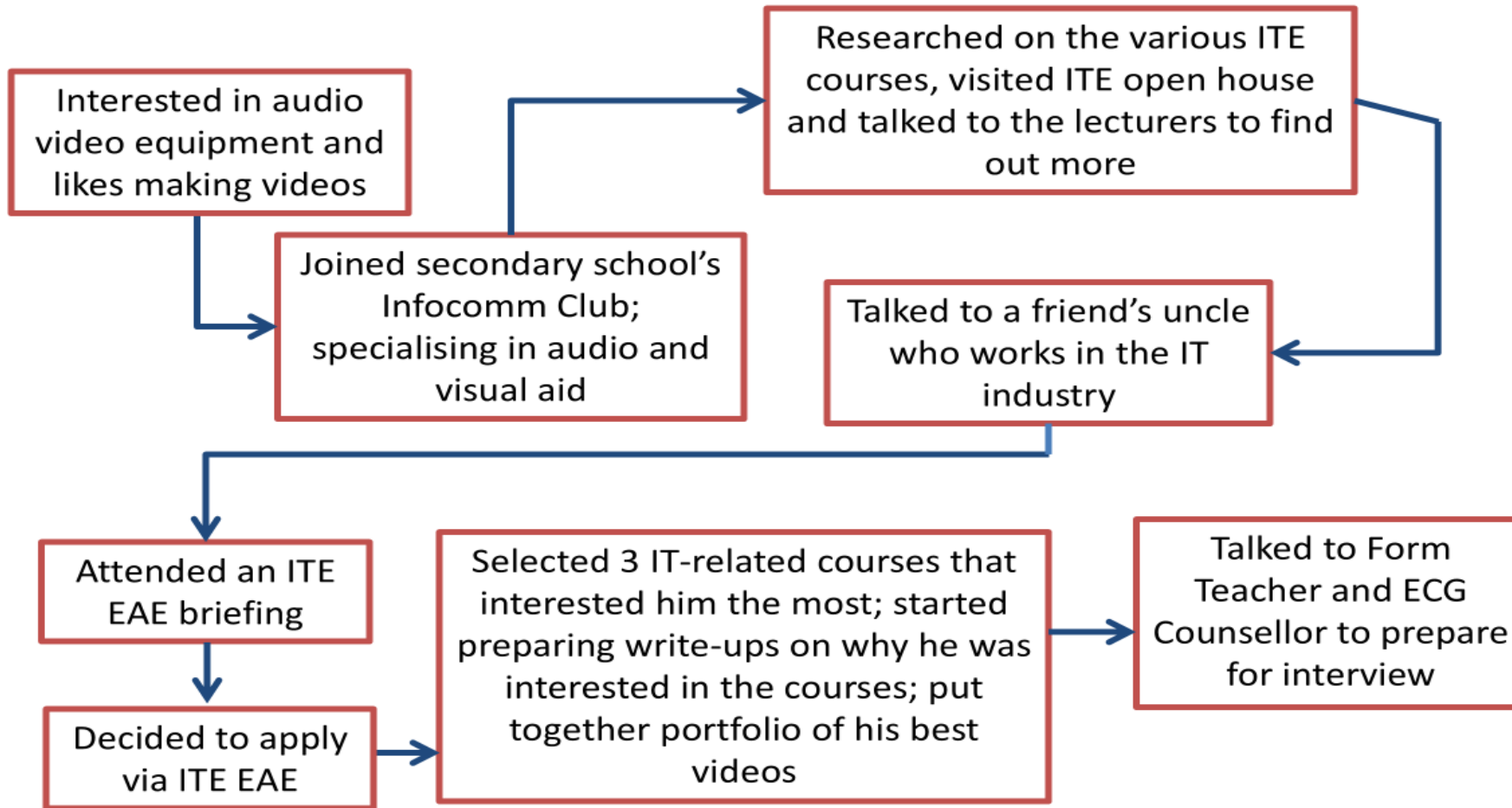

ITE EAE Process



Student Nicole's Story

EAE: Playing to a strength – Making flight possible

Nicole has always been intrigued by machines used in transport and how they are constructed. Through EAE to ITE's Aerospace Technology course, she found the chance to work on some of the most complex machines of all – the engines that enable flight.



“A boat and a plane may work differently,” she said, “but they are both **solutions humans found to transport themselves over large distances. I was very curious about how people built machines to do all this work for them!**”



“I spent a lot of time reading through the course requirements,” she shared, “and also reading up on aviation and planes so that I knew what I was getting into. **It is not something many girls would do, but the more I read, the more I wanted to learn about this industry.**”

Applied Programme (ALP) Nicole was in Science and Technology. She learned about the basics of engineering and used a computer programme to create 3D-models of products they designed.

Learning

N-level coursework for D&T, Nicole designed a device for transport. Based on the concept of a conveyor belt, the tool helps people move a box from one place to another without having to carry it.

Resource

HS School Website

The screenshot shows the website for Hougang Secondary School. The header includes the school logo and navigation menus for 'ABOUT US', 'DEPARTMENTS', 'KEY PROGRAMMES', 'CO-CURRICULAR ACTIVITIES', 'HBL-SIL', and 'QUICK LINKS'. A breadcrumb trail reads 'HOME / QUICKLINKS / FOR STUDENTS / FOR STUDENTS'. The main heading is 'For Students'. On the left, there is a vertical menu with categories: Admin, Appeal For Transfer Into HS, Assessment, Direct School Admission 2024, HBL SIL, HS ICT Helpdesk Form, For Parents, and For Students. The 'For Students' section is expanded to show links for 'Subject Combination Briefing', '2024 Sem 2 Inspire@HS', 'Science Practical Prelim Briefing Slides 2024', '2024 Sec 1 to 3 End of Year Examination Schedule And Formats', and 'Structured Consultation'. The main content area features logos for Google Workspace, the Ministry of Education Singapore, and the Student Learning Space. It also includes a Facebook icon, a QR code with the GO.gov.sg logo, and links to 'SCHOOL HUB PORTAL', 'HS Facebook', 'MySkillsFuture', and 'ECG Bookcase'.





HS ECG Padlet

The screenshot shows a Padlet digital resource hub titled 'Education and Career Guidance' with the tagline 'Discover Purpose - Explore Opportunities - Stay Relevant'. The background is a vibrant space-themed illustration. Navigation tabs at the top include 'FAQ', 'Events 2025', 'EAE 2025', 'ECGC Contact', and 'ECG Resource'. The main area displays several pinned posts: 'Pathways for "O" level students' with an 'Overview of Post O-Level Education Landscape' diagram; 'Compilation Poly / JC Open Houses 2025' with a 'DOC' table listing dates for various schools; 'THE MEDIA CHALLENGE 2025' with a poster for the 'REPUBLIC POLYTECHNIC' challenge; 'Education and Career Guidance Contact' with a QR code; and '2024 ECG BUZZ IS ARE YOU READY FOR INTERVIEWS?' with a QR code. A large QR code with the GO.gov.sg logo is positioned at the bottom right of the Padlet.







Resource



<p>ITE EAE APPLICATION PORTAL</p>	<p>ITE 2025 COURSE BOOKLET</p>	<p>NAFA NFP</p>	<p>MOE COURSE FINDER</p>
		 <p>https://go.gov.sg/nafa-fp</p>	

Resource



ITE EAE APPLICATION PORTAL	ITE 2025 COURSE BOOKLET	POLY PFP PORTAL	ITE DPP
		 <p data-bbox="1442 1219 1676 1239">https://go.gov.sg/pfp-website</p>	 <p data-bbox="1964 1200 2232 1242">https://go.gov.sg/ite-higher-nitec-dpp</p>

Resource



<p>NAFA NFP</p>	<p>MOE COURSE FINDER</p>	<p>MY SKILLS FUTURE SECONDARY KNOW YOURSELF</p>	<p>DISCOVER NYC EXPLORE INDUSTRIES</p>
 <p>https://go.gov.sg/nafa-fp</p>			

Resource



Starting from the 2026 intake, students will be admitted to the PFP in 3 broad clusters instead of a specific diploma programme.

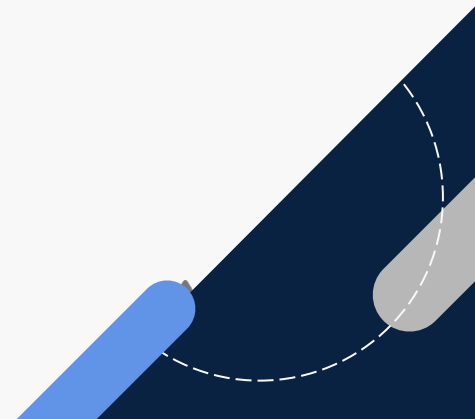

Thanks
You

